

ENGL



TUBE POWERAMP 850/100

Operator's Manual

Please, first read this manual carefully!



In addition to delivering top-notch tube tone, the **ENGL** power amp 850/100 offers a number of practical features in a powerful 2 x 100-watt package.

- **Gain Lo/Hi:** This feature adjusts input sensitivity to match levels to different preamps and FX processors.
- Each Left and Right stereo channel features A and B volume controls that let you dial in different volume settings. Volume A/B may be selected via a footswitch or an external MIDI Switcher (e.g. ENGL Z-11). You're sure to find that Volume A/B comes in very handy, especially when playing alternating rhythm and lead parts.
- The Sound Set circuit is a brand-new ENGL innovation featured for the first time in the 850/100 Power Amp. It features two dedicated EQ systems including Presence A and Depth A (for Sound Set A) and Presence B and Depth B (for Sound Set B). You can dial in two different power amp setups and match them up with a clean and a lead configuration on the connected preamp to achieve excellent tonal results. Sound Set A/B is selected via a footswitch or an external MIDI Switcher (e.g. ENGL Z-11).
- The 850/100 is equipped with impedance-matched 4-, 8- and 16-ohm speaker outputs for virtually any kind of cabinet configuration you care to devise.
- Dedicated Standby switches for the power amp's left and right channels enable single-sided operation.
- Two safety systems are on board: Four power tube fuses protect the amp from damage brought on by power tube defects/failure and ensure the amp does not shut down. It continues to function on both channels, though the defective channel operates at a reduced power output level. In addition, a thermal overload protector deactivates both channels in the event of internal overheating due to fan failure.

This power amp's hallmarks include intelligent design features, superior craftsmanship, impeccable finishing and highest quality components. Bear in mind, though, that a few precautions will dramatically extend tube life (see handling and care guide). The ENGL team would like to thank you for your confidence in our product. We certainly enjoyed engineering this fine work of audio art for you, and hope the ENGL 850/100 TUBE POWER AMP brings you just as much joy and satisfaction.

PLEASE NOTE: Read the Operator's Manual carefully and thoroughly, especially the Handling and Care section as well as the guidelines in bold-face type. Avoid operating errors and potential damage to the power amp by heeding the guidelines and cautionary remarks in this manual. The footnotes marked "T" also offer a few helpful pointers and interesting tips covering several functions. These are listed on page 3 of the manual.

CAUTION! Please read and heed the following:

You'll find an ancillary pamphlet accompanying this owner's manual entitled *Instructions for the Prevention of Fire, Electrical Shock and Injury*. Be sure to read it before you plug in and power up the amp!

Front Panel

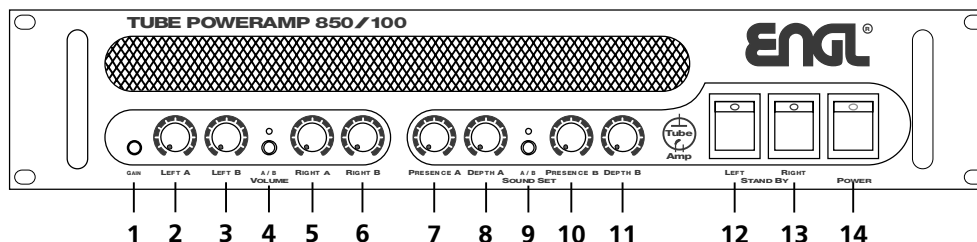

- | | |
|---|--|
| <p>1 GAIN Hi/Lo
Adjusts power amps' input sensitivity.
Low: ca. -10 dBV, High: ca. -25 dBV;</p> <p>2 VOLUME LEFT A
Volume control A for the left power amp.</p> <p>3 VOLUME LEFT B
Volume control B for the left power amp.</p> <p>4 VOLUME A / B
switches between VOLUME A and VOLUME B,
T 1 1. "off position" (button not engaged):
VOLUME A active: red LED off;
2. "on position" (button engaged):
VOLUME B active: red LED lights up;
This feature can also be remote-controlled
via a footswitch or a MIDI Switcher connected
to jack 18; the VOLUME A/B pushbutton is
deactivated once a footswitch is connected.</p> <p>5 VOLUME RIGHT A
Volume control A for the right power amp.</p> <p>6 VOLUME RIGHT B
Volume control B for the right power amp.</p> <p>7 PRESENCE A
Power amp treble control A; affects both
left and right channels.</p> <p>8 DEPTH A
Power amp bass control A; affects both
left and right channels.</p> <p>9 SOUND SET A / B
T 2 Switches between Sound Set A
(Presence A & Depth A) and
Sound Set B (Presence B & Depth B),
1. "off position" (button not engaged):
Sound Set A active: red LED off;
2. "on position" (button engaged):
Sound Set B active: red LED lights up;
This feature can also be remote-controlled
via a footswitch or a MIDI Switcher connected
to jack 18; the Sound Set A/B pushbutton is
deactivated once a footswitch is connected.</p> | <p>10 PRESENCE B
Power amp treble control B; affects both
left and right channels.</p> <p>11 DEPTH B
Power amp bass control B; affects both
left and right channels.</p> <p>12 STANDBY LEFT
T 3 Left channel standby switch,;
Use this switch to silence ("0" indicated) the left
channel when you take a longer break. The
power amp's tubes stay nice and toasty, and
the channel is ready to roll immediately when
you ramp it back up to full power. If you wish
to use the right channel only, you must
deactivate the left channel with the
Standby switch.
Reset function for the thermal overload
protector: Please consult the "Troubleshooting"
section for details.</p> <p>13 STANDBY RIGHT
T 3 Right channel standby switch,;
Use this switch to silence ("0" indicated) the right
channel when you take a longer break. The
power amp's tubes stay nice and toasty, and
the channel is ready to roll immediately when
you ramp it back up to full power. If you wish
to use the left channel only, you must
deactivate the right channel with the
Standby switch.
Reset function for the thermal overload
protector: Please consult the "Troubleshooting"
section for details.</p> <p>14 POWER
Mains power on/off.</p> |
|---|--|

Rear Panel

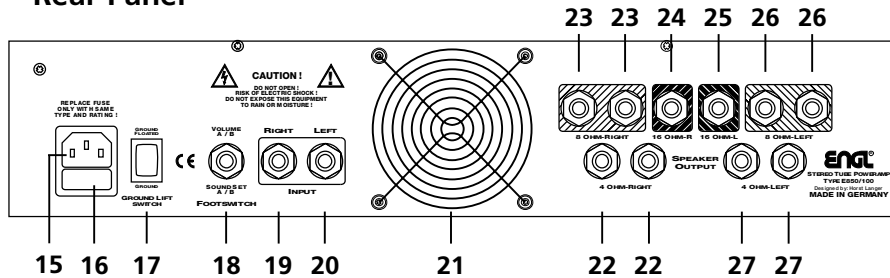

15 AC Socket

connect an AC cord here.

NOTE: Ensure you use an intact AC cord with an insulated plug only! Before you power the amp up, ensure the voltage rating printed above the AC socket matches the local current!

16 AC Fuse Box

contains the mains fuse (rear chamber) and one spare fuse (front chamber).
NOTE: Ensure replacement fuses bear identical ratings (refer to the table)!

17 GROUND LIFT SWITCH

T 4 GROUND position: Power amp and outlet grounds are connected directly.
GROUND FLOATED position: Power amp and outlet grounds are not connected directly.
=> Use this feature to prevent ground loops in setups with other grounded 19" units.

18 FOOTSWITCH: VOLUME A/B, SOUND SET A/B

T 5 This 1/4" stereo jack accepts a dual footswitch to:

1. Switch between VOLUME A and VOLUME B (Mono contact).
2. Switch between SOUND SET A and SOUND SET B (Stereo contact).

19 INPUT RIGHT

The right power amp channel's signal input.

20 INPUT LEFT

The left power amp channel's signal input.

21 Fan Shaft

An ultra-quiet fan ensures your poweramp remains cool; fresh air is sucked in via this shaft.

ATTENTION: Install the amp in a 19" rack in such a manner as to ensure air circulation is not impeded.

Do not block or cover the fan shaft, the side and the front coolant vents.

22 SPEAKER OUTPUT:

T 6 **4 OHM PARALLEL RIGHT**
4-ohm right channel speaker output jacks; internal parallel circuit for connecting one 4-ohm cabinet or two 8-ohm cabs.

23 SPEAKER OUTPUT:

T 6 **8 OHM PARALLEL RIGHT**
8-ohm right channel speaker output jacks; internal parallel circuit for connecting one 8-ohm cabinet or two 16-ohm cabs.

24 SPEAKER OUTPUT: 16 OHM RIGHT

T 6 16-ohm right channel speaker output jack for connecting one 16-ohm cabinet.

25 SPEAKER OUTPUT: 16 OHM LEFT

T 6 16-ohm left channel speaker output jack for connecting one 16-ohm cabinet.

26 SPEAKER OUTPUT:

T 6 **8 OHM PARALLEL LEFT**
8-ohm left channel speaker output jacks; internal parallel circuit for connecting one 8-ohm cabinet or two 16-ohm cabs.

27 SPEAKER OUTPUT:

T 6 **4 OHM PARALLEL LEFT**
4-ohm left channel speaker output jacks; internal parallel circuit for connecting one 4-ohm cabinet or two 8-ohm cabs.

IMPORTANT NOTE: If you choose to use just one power amp channel, ensure you switch the other channel's STANDBY switch off. Never operate an active stereo channel without a connected speaker, you may destroy the power amp! Ensure your cabinet's specifications match the respective output's specs!

- T 1** *VOLUME A/B switching serves to activate two different volumes: In combination with a preamp, you can dial in one level for rhythm work, and the other for leads, or even two different levels for soloing.*
- T 2** *Benefits and practical application of Sound Set A/B switching: This feature lets you combine various preamp configurations with the two power amp EQ setups Sound Set A and B, easily and conveniently. You can tweak the power amp to shape the tone in different ways using the two Sound Set EQs, thereby considerably extending your sonic spectrum.*
The two power amp EQs let you sculpt different basic sounds, say clean and lead, with great precision, so you can dial in exactly the sound you wish to hear. Let's look at a typical example using a multi-channel preamp (that is, a dual clean/lead-channel device):
Sound Set A:
PRESENCE A knob setting between 1 and 4 o'clock;
DEPTH A knob setting around 12 o'clock;
Sound Set B:
PRESENCE B knob setting between 9 and 1 o'clock;
DEPTH B knob setting somewhere in the 3-to-4 o'clock range;
Activate the preamp's clean channel and Sound Set A: Lots of high end and a moderate amount of low end yield crisp clean tone. Activate Sound Set B for the preamp's lead channel (that is, overdriven preamp). Reduced treble and plenty of low-end punch yield warm, assertive lead tone.
- T 3** *I suggest you get into the habit of using standby during short breaks. In this mode, current is not piped through the power tubes, so they don't get as hot (due to the lack of anode dissipation) and are spared considerable wear. The power amp is ready to run when you flip the Standby switch because the tubes are already warm and don't require time to heat up. For breaks of 30 minutes and longer, I recommend that you switch the poweramp off in order to conserve energy.*
- T 4** *If you encounter a ground loop in your 19" rack (usually caused by a duplicate connection between grounded devices and the audio signal ground), you can sever the ground from the housing by setting the GROUND LIFT switch to the GROUND FLOATED position.*
- T 5** *The switching functions VOLUME A/B and SOUND SET A/B can also be executed via a looper/switcher or other MIDI devices that feature two freely-programmable (switching-) inputs. Depending on the type of MIDI device, you may have to split the FOOTSWITCH stereo jacks into two mono jacks. Each switching function requires the mono or stereo contact see 18 for assignments and the ground!*
NOTE! If the switching and signal grounds are identical in the MIDI device, then you may encounter a ground loop, especially if the amp and device (e.g. FX processor) exchange signals!
- T 6** *Choose only one of the following cabinet options for each channel:*
A. One 4-ohm cabinet connected to a 4-ohm jack,
B. Two 8-ohm cabinets connected to the 4-ohm jacks,
C. One 8-ohm cabinet connected to a 8-ohm jack,
D. Two 16-ohm cabinets connected to the 8-ohm jacks,
E. One 16-ohm cabinet to the 16-ohm jack.
If you are using one stereo speaker cabinet for both channels, ensure it actually operates in stereo mode, otherwise you may damage the power amp!

Technical Data

Rated power:	approx. 2 x 100 watts;
Outlet impedance each channel:	4, 8 and 16 ohms;
Input Sensitivity:	GAIN Lo: -10 dBV max. 10 dBV; GAIN Hi: -25 dBV max. -5 dBV;
Tubes:	
V1, input tube, both channels:	ECC83/12AX7 selected;
V2, phase splitter left channel:	ECC83/12AX7 standard;
V3, phase splitter right channel:	ECC83/12AX7 standard;
V4 - V7, power tubes left channel:	6L6GC, matched set;
V8 - V11 power tubes right channel:	6L6GC, matched set;
Fuses and Power consumption:	
AC Mains:	230 Volts and 240 Volts: 2,5 ATL (slow blow) 100 Volts and 120 Volts: 5 ATL (slow blow)
Power Tube Fuses:	4 x 315 mAM (medium blow)
Caution: Replace fuses only with others of the same rating!	
Power consumption:	approx. 650 VA, max.;
Dimensions:	19", 2 rack spaces, depth: 350 mm (including handles: 390 mm)
Weight:	approx. 17 kg;

Tube array

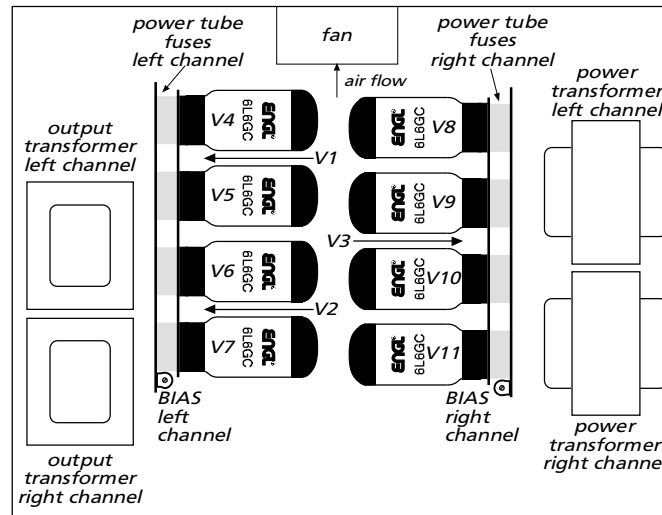

ENGL Gerätebau GmbH - Germany - web: <http://www.engl-amps.com>
Text & design, graphics & layout by Horst Langer, ENGL Amp Designer

Troubleshooting

Power amp will not switch on.

- > Does the necessary voltage level exist at the receptacle?
- > Is the power cord o.k.? Test it through exchanging it.
- > The mains fuse may have blown. Check the fuse and replace it with a fuse of the same type and rating. If necessary, you'll find a spare fuse in the mains fuse box's front chamber

The amp is not providing an output signal / no sound is emanating from the speaker.

- > Is at least one speaker connected to the speaker outputs Right and/or Left 4, 8, or 16 ohms (22, 23, 24, 25, 26, 27)?
- > Is the respective power amp channel activated (Standby switch to ON)?
- > Are all cords (guitar, effect, and speaker) connected properly and are they functional? (-> Is there a break or short circuit in a cord?)
- > Unplug connected preamps and effectors and see if the poweramp works fine without these peripheral devices. Plug in your guitar to the respective Input jack and set the Gain option to "Hi".
- > Are the active Volume knobs of the given power amp channel set to a value greater than 0? If any of these knobs is set to 0, no signal is routed to the power amp's outputs.
- > Is the temperature in the power amp extremely high? The thermal protector may have engaged. Set both Standby switches to the off position ("0") and allow the amp to cool down before powering it up again.
- > A tube, internal fuse or other component may be defective. Be sure to take the amp to an authorized service center.

A power amp channel's output is far too low.

- > A defective power tubes caused one of the fuses to trip. Have a qualified specialist check the power amp fuses and replace them if necessary. The tube that caused the problem must also be checked and replaced to ensure the fuse doesn't trip again. Note that fine-wire fuse protects a pair of tubes.

The speaker is emitting humming noises:

- > Is the Ground Lift switch (17) set to Ground? If you are operating the power amp with other grounded gear (preamp, effect devices) connected, this switch must be set to the "Ground Floated" position in order to prevent ground loop hum. You may even hear humming even without a guitar connected to your rig. Set the Ground Lift switch to the "Ground" position if the other connected devices are not grounded (this is usually the case with external power supply units and mains plugs lacking a ground terminal).
- > The two patch cords connecting the two L & R preamp outputs to the L & R power amp inputs are another potential noise source. The duplicate ground circuits can cause hum, depending on the type of cords and their routing. You can solve this problem by severing one of the two patch cords' ground circuits, either by detaching the ground wire from one of the two patch cords or by masking the ground terminal on the jack plug using insulating tape.
- > The amp and mains grounds are not connected properly or are altogether disconnected. Have an experienced specialist check this.
- > Cords connected to the input may not be shielded properly. Replace them to check if this is indeed the case.
- > The poweramp, signal or speaker cords or another unit in the setup may be picking up interference from powerful magnetic fields (for example, of nearby power transformers or electrical motors). Reposition the amp and connector cables.
- > The poweramp, signal or speaker cords or another unit in the setup may be picking up radio signals, for example, from activated mobile telephones or powerful local transmitting stations nearby. Switch off mobile phones while troubleshooting noise problems.

Overheat protection circuit:

If the temperature inside the power amp rises to an excessive level (around 80°C), a temperature monitor switches both power amp channels off to protect components. Extreme temperatures such as this can have several causes, for example, markedly inadequate circulation; when both power amp channels are operated continuously at high loads and ambient temperatures are very high; or in the event that the internal fan is defective. To reset this protection circuit, wait for the amp to cool down (about 20 minutes, depending on the prevailing ambient conditions). Set both Standby switches to the off position ("0" indicated) and then reactivate the power amps.

Handling and Care

- *Protect the poweramp from mechanical knocks (-> tubes!)*
- *Let the poweramp cool down before you transport it (-> for about 10 minutes).*
- *It takes tubes some 20 seconds to warm up after you switch the power on, and another a few minutes before they operate at full power.*
- *Avoid storing the poweramp in damp or dusty rooms, they are hard on jacks, switches and potentiometers.*
- *Ensure air can circulate at the rear (fan shaft), the front and both sides of the power amp to allow for adequate cooling (increases component life).*
- *Never operate an active poweramp channel without an adequate load!*
- *Replace tubes with select **ENGL** replacement tubes (special selection criteria) to avoid microphonic properties, undesirable noise and unbalanced performance.*

Attention! Please read the following!

- ***This amp can produce very high volume levels. Exposure to high volume levels may cause hearing damage!***
- ***Leave tube replacement and power amp biasing to a qualified professional. Ensure the unit is switched off and unplugged!***
- ***Caution - tubes can get very hot and burn your skin!***
- ***Always use high-quality cables.***
- ***Never operate the power amp via an ungrounded outlet!***
- ***Never bridge a defective fuse; always ensure replacement fuses have identical ratings!***
- ***Pull the AC mains plug before replacing fuses!***
- ***Never open the chassis or attempt repairs on your own. Consult qualified service personnel!***
- ***Never expose the amplifier to extreme humidity or dampness!***
- ***Please read the instructions carefully before operating the unit!***

Technical specifications are subject to change without notice.